

RED SWASTIKA SCHOOL  
SCIENCE  
PRIMARY 5  
CLASS TEST (2)

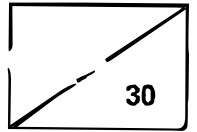

Name: \_\_\_\_\_ ( ) Parent's Signature: \_\_\_\_\_

Class: Pr. 5 \_\_\_\_\_ Date: \_\_\_\_\_



Total time for Section A and B: 45 minutes

**Section A: Multiple-Choice Questions (9 x 2 = 18 marks)**

Choose the most suitable answer and shade its number in the OAS provided.

1. Which of the following graphs correctly shows the amount of digested and undigested food as it leaves the mouth, stomach and small intestine?

Legend:

	undigested food
	digested food

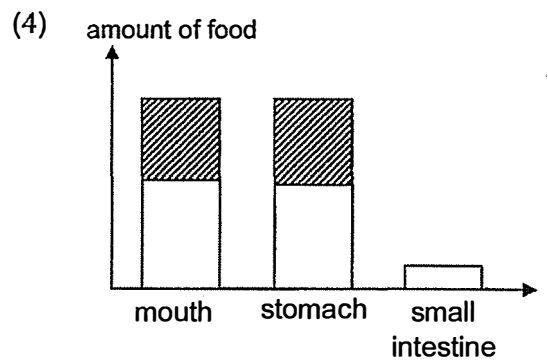
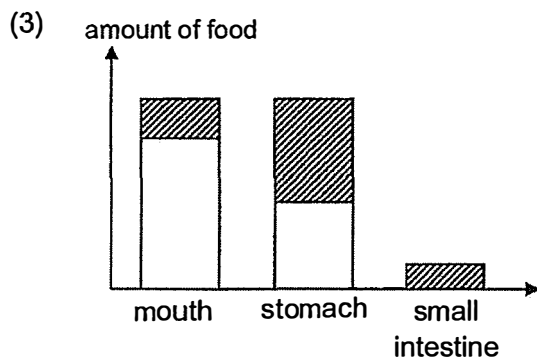
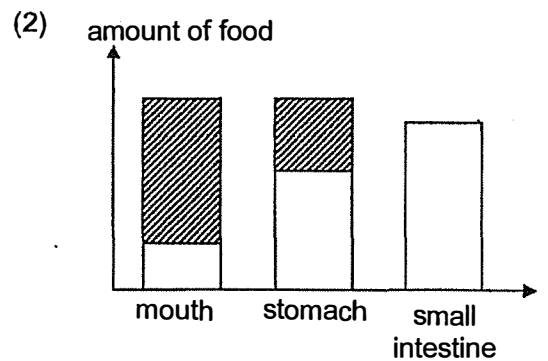
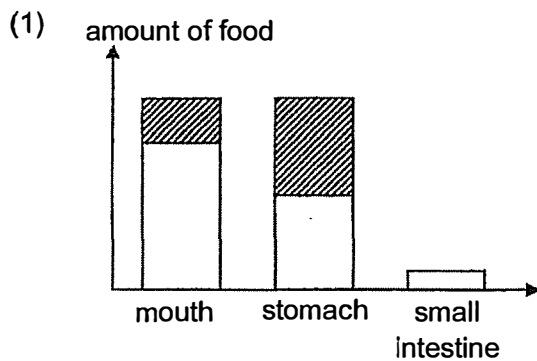

2. Oliver wanted to conduct an experiment to find out if the presence of light affects the growth of a plant. He put four similar plants into four identical pots and gave each plant the same amount of water each day.

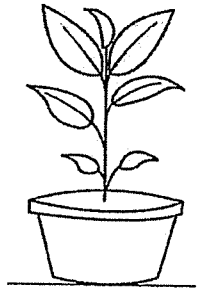

**Plant P**  
(in the cupboard)

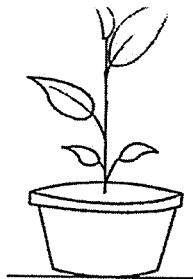

**Plant Q**  
(in the cupboard)

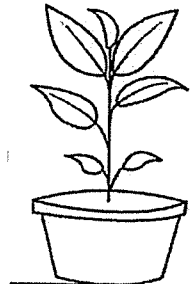

**Plant R**  
(in the garden)



**Plant S**  
(in the garden)

Which two set-ups should Oliver choose in order to carry out a fair test?

- (1) P and Q only
- (2) P and R only
- (3) Q and S only
- (4) R and S only

3. The diagram below shows systems A and B in a human body. The arrows represent blood transporting substances X and Y.

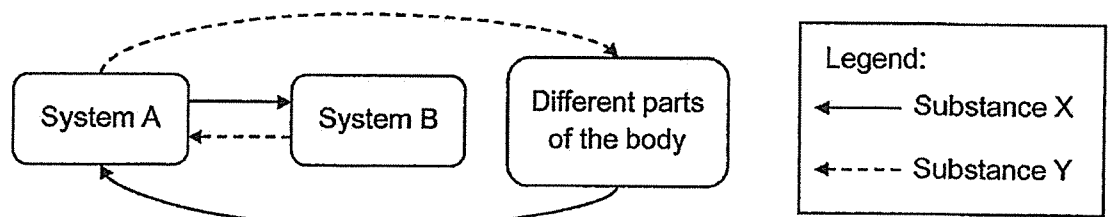

Which of the following options correctly represents systems A and B as well as substances X and Y?

	System A	System B	X	Y
(1)	respiratory	circulatory	carbon dioxide	oxygen
(2)	respiratory	circulatory	oxygen	carbon dioxide
(3)	circulatory	respiratory	carbon dioxide	oxygen
(4)	circulatory	respiratory	oxygen	carbon dioxide

4. The table below shows the composition of gases in air that are inhaled and exhaled by a child.

Gas	Inhaled air (%)	Exhaled air (%)
Nitrogen	78	78
Oxygen	21	16
Carbon dioxide	Less than 1	4
Water vapour	Less than 1	2

Based on the information provided, which of the following statements is correct?

- (1) All oxygen is taken in by the body.
- (2) Most oxygen is given out by the body.
- (3) Some nitrogen is taken in by the body.
- (4) Carbon dioxide is produced by the body.

5. The food-carrying tubes between positions X and Y of a plant's stem were removed, leaving behind the water-carrying tubes.

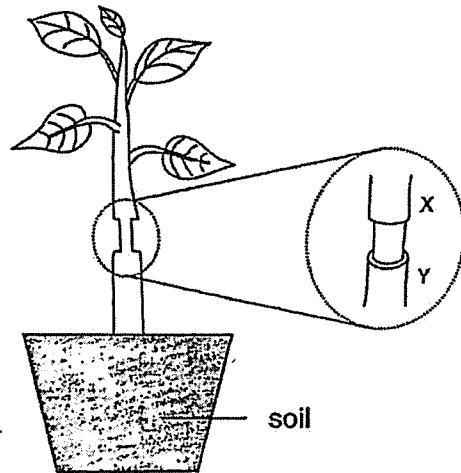

After some time, which of the following diagrams would best represent how the stem would look?

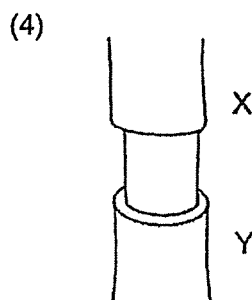
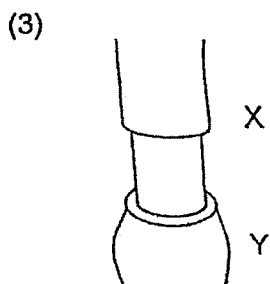
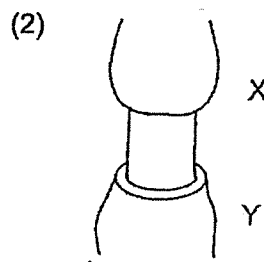
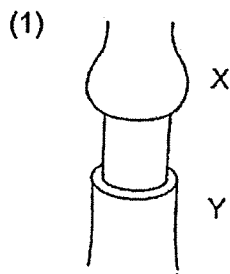

6. Ariff conducted two experiments with two balls, P and Q, of similar shape and size. The set-ups are as shown below.

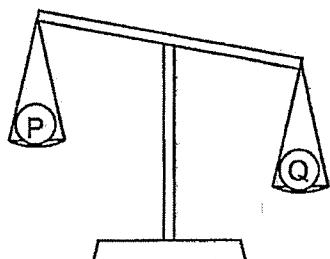

**Set-up 1**

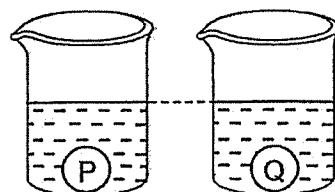

**Set-up 2**

Based on the results of the experiment above, what can he conclude about P and Q?

- (1) P has a larger mass than Q.
  - (2) Q has a larger mass than P.
  - (3) P occupies less space than Q.
  - (4) Q occupies less space than P.
7. The diagram below shows a container with a capacity of  $500 \text{ cm}^3$  and a plunger fitted to it. Each time the plunger is pulled completely,  $20 \text{ cm}^3$  of air is drawn out of the container.

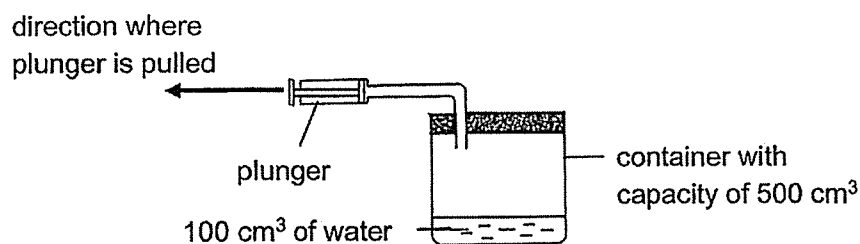

Which of the following correctly shows the change in the volume and mass of both air and water in the container after the plunger is pulled completely once?

	Volume of air	Mass of air	Volume of water	Mass of water
(1)	Decreased	Remains the same	Decreased	Remains the same
(2)	Decreased	Decreased	Remains the same	Decreased
(3)	Remains the same	Remains the same	Remains the same	Remains the same
(4)	Remains the same	Decreased	Remains the same	Remains the same

8. Derrick walked in a straight line at the same pace from point A to point C.

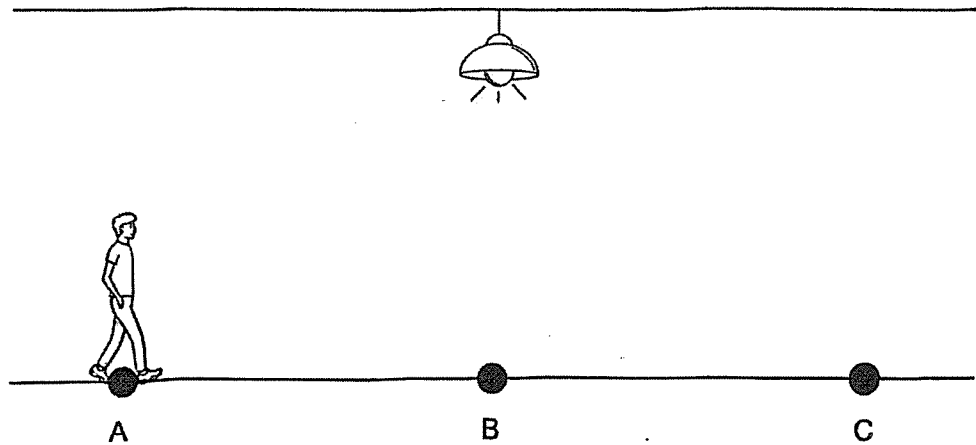

Which of the following graphs correctly shows how the length of Derrick's shadow will change as he walks from point A to point C?

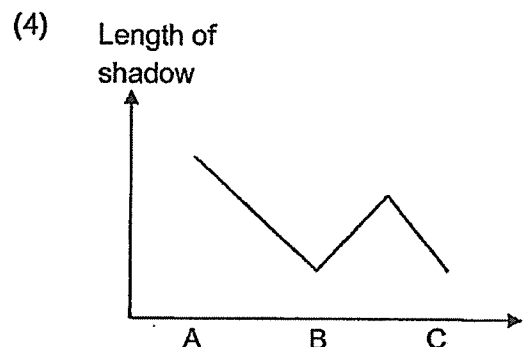
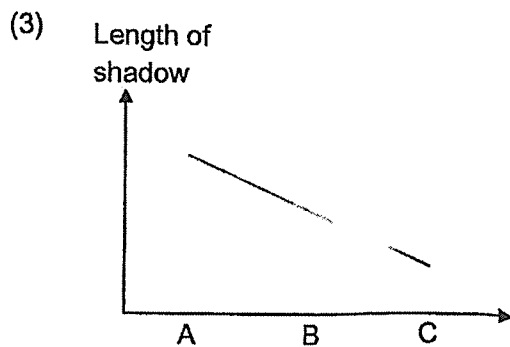
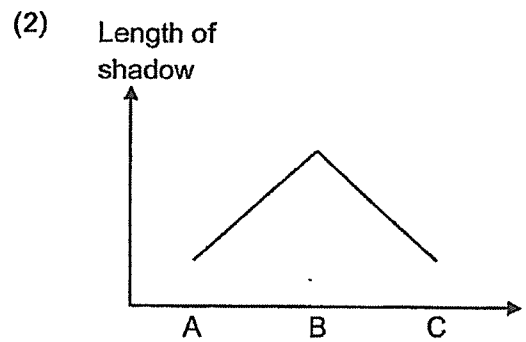
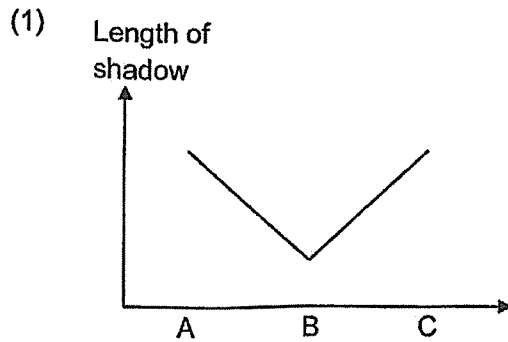

9. Vera placed four different materials, P, Q, R, S, in a straight line as shown below.

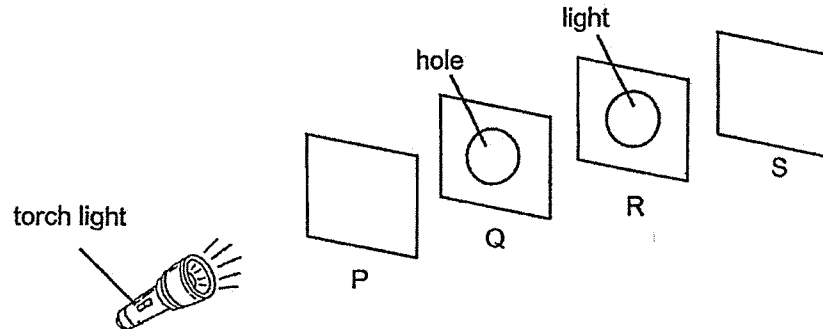

When Vera switched on the torch and placed it in front of material P, she observed a patch of light shining on material R, but not on materials P or S.

Which of the following statements can be concluded from her experiment?

- A: Material P allows most light to pass through it.
- B: Material R allows no light to pass through it.
- C: Material S allows some light to pass through it.

- (1) A only
- (2) B only
- (3) A and B only
- (4) A and C only

**Section B: Open-ended Questions (3 Questions: 12 marks)**

10. Oliver wore an object that measured and recorded his heart rate before he started exercising, while he was jogging and then running.

The results of his exercise were compiled and then shown in the graph below.

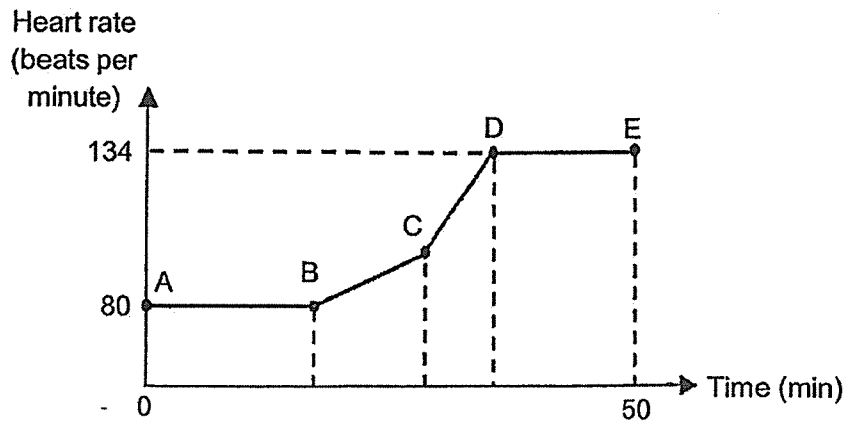

- (ai) State which points of the graph, A, B, C, D or E, Oliver started jogging and running. (1m)

Jogging: \_\_\_\_\_

Running: \_\_\_\_\_

- (aii) After 50 minutes, Oliver stopped running and rested for 10 minutes. Predict what his heart rate would be after he rests for 10 minutes. (1m)

\_\_\_\_\_ beats per minute

- (b) Oliver noticed that his breathing rate and heart rate increased when he started jogging. Explain how the respiratory system works together with the circulatory system during his exercise. (2m)

---

---

---

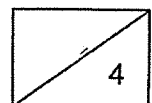

11. The diagram below shows how food and water are transported to parts R, S and T of a plant.

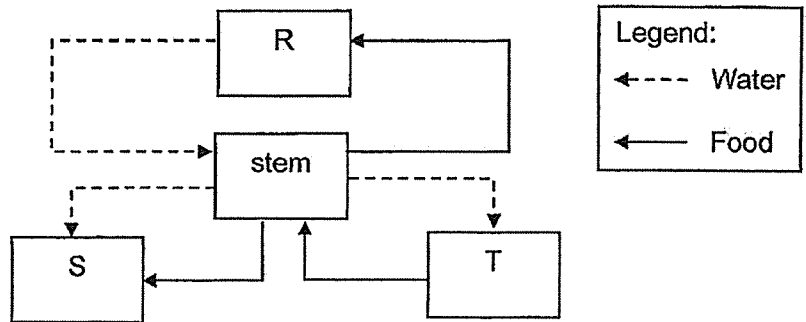

- (a) Which letters represent the plant parts below? (2m)

Leaf: \_\_\_\_\_

Flower: \_\_\_\_\_

- (b) The food-carrying tubes at section Q were removed from a plant as shown in the diagram below.

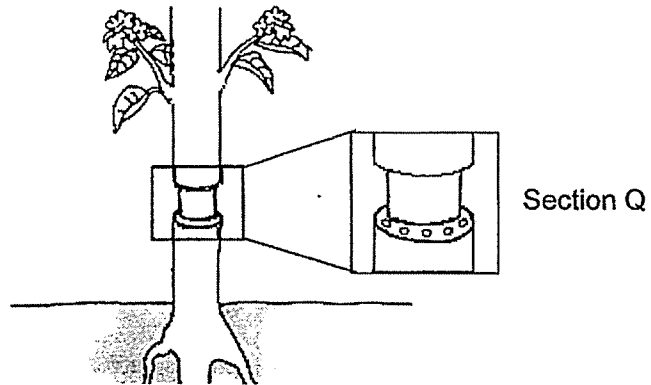

Explain why the plant wilted and died after a few days. (2m)

---



---



---

12. When a lake is polluted, there is dirt in the water, which makes it difficult for plants to obtain light to make food. Water samples were taken from three different lakes, R, S and T, to check how polluted the lakes were.

Light was shone with a torchlight through three similar clear glass beakers. The beakers contain water samples from R, S, and T as shown below.

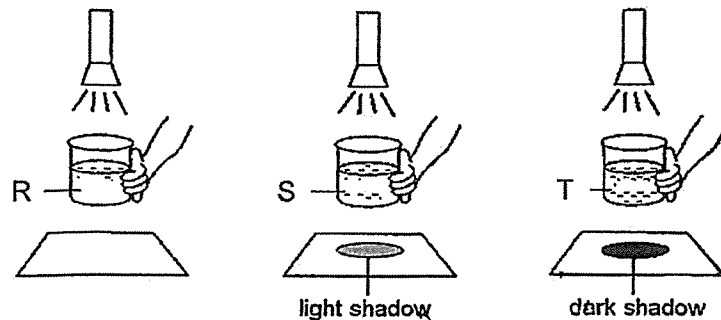

- (ai) State how shadows are formed. (1m)

---

- (aii) From the diagram above, which lake is the most polluted? Explain your answer. (1m)

---



---

- (b) Which are the variables that must be kept constant in order for the experiment to be a fair test? Place a tick (✓) next to it. (2m)

Variable	Tick (✓)
Size of shadow cast	
Material of beaker used	
Volume of water sample obtained	
Distance between torch and beaker	
Lake where water sample was obtained	

**End of Paper**  
Please check your answers.

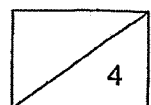

**SCHOOL : RED SWASTIKA PRIMARY SCHOOL**  
**LEVEL : PRIMARY 5**  
**SUBJECT : SCIENCE**  
**TERM : 2025 WEIGHTED ASSESSMENT 2**

Q1	Q2	Q3	Q4	Q5	Q6	Q7	Q8	Q9	
1	2	3	4	1	2	4	1	3	

Q10	<p>a)</p> <p>i) Jogging B , Running C</p> <p>ii) 80</p> <p>b) More oxygen is taken in. More oxygen enters the bloodstream in the lungs. The heart will pump more blood. Blood rich in oxygen will be transported to different parts of the body.</p>
Q11	<p>a)</p> <p>Leaf: T</p> <p>Flower: S</p> <p>b) Food in the leaves cannot be transported to the roots. The roots will be without food and cannot absorb water for the plant causing it to die.</p>
Q12	<p>a)</p> <p>i) Light is partially or completely blocked by an object.</p> <p>ii) T. The water sample from T cast the darkest shadow, showing that there was the most dirt in the lake blocking the most light.</p>

